

# 24" FOLDABLE WHEELCHAIR

**Model 67437**

## SET UP AND OPERATING INSTRUCTIONS



Distributed exclusively by Harbor Freight Tools®.

3491 Mission Oaks Blvd., Camarillo, CA 93011

Visit our website at: <http://www.harborfreight.com>



**Read this material before using this product.  
Failure to do so can result in serious injury.  
SAVE THIS MANUAL.**

---

Copyright© 2009 by Harbor Freight Tools®. All rights reserved. No portion of this manual or any artwork contained herein may be reproduced in any shape or form without the express written consent of Harbor Freight Tools. Diagrams within this manual may not be drawn proportionally. Due to continuing improvements, actual product may differ slightly from the product described herein. Tools required for assembly and service may not be included.

**For technical questions or replacement parts, please call 1-800-444-3353.**

---

## SAVE THIS MANUAL

---

Keep this manual for the safety warnings and precautions, assembly, operating, inspection, maintenance and cleaning procedures. Write the product's serial number in the back of the manual near the assembly diagram (or month and year of purchase if product has no number). Keep this manual and the receipt in a safe and dry place for future reference.

---

## IMPORTANT SAFETY INFORMATION

---

In this manual, on the labeling, and all other information provided with this product:



This is the safety alert symbol. It is used to alert you to potential personal injury hazards. Obey all safety messages that follow this symbol to avoid possible injury or death.

**⚠ DANGER** DANGER indicates a hazardous situation which, if not avoided, will result in death or serious injury.

**⚠ WARNING** WARNING indicates a hazardous situation which, if not avoided, could result in death or serious injury.

**⚠ CAUTION** CAUTION, used with the safety alert symbol, indicates a hazardous situation which, if not avoided, could result in minor or moderate injury.

**NOTICE** NOTICE is used to address practices not related to personal injury.

**CAUTION** CAUTION, without the safety alert symbol, is used to address practices not related to personal injury.

---

### General Safety Warnings



**WARNING** Read all safety warnings and instructions. *Failure to follow the warnings and instructions may result in electric shock, fire and/or serious injury.* Save all warnings and instructions for future reference.

1. Do not exceed 250 lb. maximum weight capacity of Wheel Chair.
2. Before using Wheelchair, check with physician(s) to make sure this Wheelchair is appropriate for the user's needs.
3. The position of the Front Casters, and Rear Wheels directly affect the Wheelchair's stability. Any modification to Casters or Wheels may cause Wheelchair to decrease in stability. **Any adjustments must**

- be made by a qualified service technician.
4. **Before riding, have a physician or health care advisor train you in safe use of Wheelchair.**
  5. **Do not try a maneuver on your own until you are sure it can be done safely.**
  6. **Do not lean forward out of the Wheelchair further than the length of the armrests. *Doing so may cause the Wheelchair to tip over. Other guidelines to prevent tipping include:***
    - a. **Do not attempt to reach objects by moving forward on the Wheelchair seat.**
    - b. **Do not attempt to reach objects by reaching between your knees.**
    - c. **Do not lean over the top of the backrest.**
  7. **Do not attempt to stand on Wheelchair or the Wheelchair's frame.**
  8. **Do not attempt to slow down or stop a moving Wheelchair with the Wheel Locks.**
  9. **When transferring to or from the Wheelchair, do not stand or put weight on the footplates or footrests. *Doing so can cause the Wheelchair to tip and lead to potential injury***
  10. **Do not sit or transfer into Wheelchair unless it is fully unfolded.**
  11. **When propelling the Wheelchair, carefully use the wheel hand rails. *Do not grip the rear wheel themselves and be careful not to pinch fingers and hand in wheel spokes.***
  12. **Use the Wheel Locks on both Rear Wheels whenever entering or exiting the Wheelchair.**
  13. **People with limited strength and mobility will need assistance when moving in and out of Wheelchair.**
  14. **Stay alert, watch what you are doing and use common sense when operating Wheelchair. The attendant should not push this Wheel Chair while tired or under the influence of drugs, alcohol or medication. *A moment of inattention while operating Wheelchair may result in serious personal injury.***
  15. **Dress properly. Do not wear loose clothing, jewelry or any items that could get caught in the wheels during use.**
  16. **Keep proper footing and balance at all times when pushing the Wheelchair. *Proper footing and balance enables better control of Wheelchair in unexpected situations.***
  17. **Keep children who are not patients away from Wheelchair. *Do not allow children to ride in, on, or push the Wheelchair without adult supervision.***
  18. **Consult health care advisor before making any modification to the Wheelchair. *Unauthorized modifications or use of unauthorized parts may change the Wheelchair***

*structure, leading to possible personal injury and property damage.*

19. **Use extra care when using Wheelchair on a wet, icy or oil-slicked surface.** *Do not use Wheelchair in shower, pool or other body of water. Dry Wheelchair as soon as possible if it does get wet.*
20. **Do not operate Wheelchair in sand, loose soil or over rough terrain.** *Doing so may damage wheels or axles or loosen the fasteners.*
21. **When using Wheelchair outside and at night, use reflective tape on Wheelchair and on clothing.** *Be sure to make eye-contact with drivers and adhere to crosswalks. It may be difficult for some drivers to spot Wheelchair at certain intersections; use extra caution during street use.*
22. **Do not use Wheelchair on busy roads, streets or highways.** *Use only on pedestrian walking areas.*
23. **Scan area well ahead of Wheelchair during use.** *Avoid obstacles when possible and make sure floor areas at home and work are level. Remove or cover threshold strips between rooms.*
24. **Do not attempt to climb or descend curbs or steps alone or without assistance unless proficient enough to make such maneuvers on your own.**
25. **Do not attempt to climb a high curb or step 4" or higher unless you have assistance.** *Attempting to climb high steps can lead to loss of balance and potential tip over.*
26. **Do not use Wheelchair on stairs without assistance.** *Doing so can lead to loss of balance and a fall, leading to potential serious injury.*
27. **Be aware that regular and intensive impact of dropping down from a high curb or step can cause damage to fasteners and lead to potential Wheelchair damage.**
28. **Do not use Wheelchair on an escalator, even with assistance.** *Doing so will most likely lead to a fall and potential serious injury.*
29. **Install and use ramps at entry and exit doors whenever possible.** *Make sure no drop off points are at bottom of ramps.*
30. **Do not use Wheelchair on slope steeper than 9% (one foot in elevation per every nine feet of slope length.)**
31. **Go straight up and straight down ramps; do angle or cut corners on ramps.** *Stay in center of ramp and do not change Wheelchair direction or stop while on slope or ramp.*
32. **Do not use rear Wheel Locks to slow down or stop Wheelchair while on a slope or ramp.**
33. **Verify that ramps at home and work meet all local legal requirements.**
34. **Do not push or pull on stationary objects (such as furniture or doorjamb) to propel Wheelchair.**
35. **Use assistance when moving into vehicle until you are safely able**

- to transfer yourself without injury.** *Lock rear wheels before transfer and move Wheelchair as close as possible to vehicle seat.*
36. **Do not allow feet to catch in the space between footrests during transfer in and out of Wheelchair.**
37. **Keep footrests at least 2” off the ground.** *If footrests are set lower, they may get caught against objects on floor.*
38. **Do not lift Wheelchair by armrest pads or footrests.** *Lift Wheelchair only by non-detachable parts of the frame.*
39. **Do not sit in Wheelchair while in a moving vehicle.** *Sit in an approved handicapped seating area and secure yourself with proper seat belts and/or vehicle restraints.*
40. **Do not transport Wheelchair in the front seat of vehicle.** *It may shift and interfere with the driver. Secure wheelchair in proper location to avoid rolling or shifting.*
41. **Do not reach or lean if you must shift weight sideways or rise up out of the Wheelchair.** *Always keep your buttocks in contact with the backrest.*
42. **Do not reach out for something with both hands.** *Doing so will keep you from catching yourself should the chair tip.*
43. **Do not lock the rear wheels when reaching for an object.** *Doing so creates a “tip-point,” which can lead to a fall.*
44. **Firmly grip a rear wheel or armrest when reaching for something.** *Doing so will help reduce the risk of a fall.*
45. **Verify both rear Rear Wheels are locked before using Wheelchair.** *An unlocked axle may come off during use and potentially lead to a fall, causing serious personal injury.*
46. **Verify Push Handle grips do not rotate or slip before use.**
47. **Do not modify or alter the Seat or any other part of the Wheelchair.**
48. **Maintain labels and nameplates on Wheelchair.** *These carry important safety information. If unreadable or missing, contact Harbor Freight Tools for a replacement.*
49. **The warnings, precautions, and instructions discussed in this instruction manual cannot cover all possible conditions and situations that may occur.** *It must be understood by the operator that common sense and caution are factors which cannot be built into this product, but must be supplied by the operator.*



**SAVE THESE  
INSTRUCTIONS.**

## SPECIFICATIONS

Weight Capacity	250 lb.
Wheelchair Width	24"
Weight	40 lb.
Wheels	Solid Rubber Tires and 360° Swivel Casters
Seat Width	20-1/4" x 16-5/8" Deep

## UNPACKING

When unpacking, make sure item is intact and undamaged. If parts are missing or broken, call Harbor Freight Tools at 1-800-444-3353.

## ASSEMBLY/OPERATIONS INSTRUCTIONS



Read the **ENTIRE IMPORTANT SAFETY INFORMATION** section at the beginning of this manual including all text under subheadings therein before set up or use of this product.

For additional information regarding the parts listed in the following pages, refer to Assembly Diagram near the end of manual.

### Unfolding/Folding

1. Before unfolding Wheelchair, make sure Rear Wheels (3) are in the locked position.
2. Hold the Armrests (10) and pull them away from one another, unfolding the Wheelchair.
3. As Wheelchair unfolds, press down on Seat (6).
4. Swivel Footplates (2) so they are horizontal.
5. To fold the Wheelchair, lock the Rear Wheels and fold Footplates up.
6. Pull up on the Seat and push Armrest closer together, folding the Wheelchair.

### Installing Foot Rests

1. Slide the Footplates (2) to the side (so that they are perpendicular to the Wheelchair. See Figure 1, below.

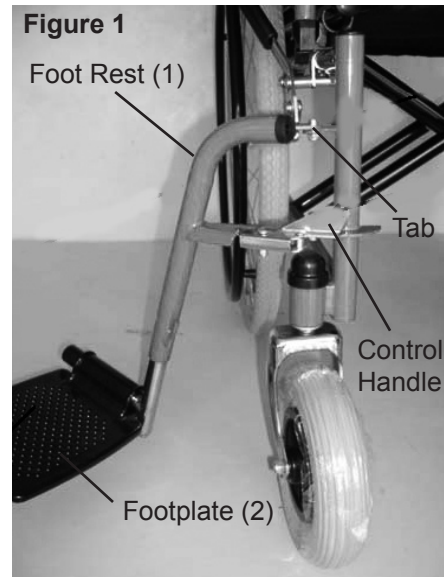

2. Install the end of each Detachable Footrest (1) onto the tab extending from the Wheelchair Frame (9). See Figure 1, above.
3. Swivel the Footrest towards the inside of the Wheel Chair until it locks into place.
4. Please note: When properly installed, Footplate will be on the inside of the Wheel Chair when locked into place.
5. To remove, push the Control Handle out and lift the Foot Rest off the Wheelchair. See Figure 1, above.



## Adjusting Foot Rests

1. To adjust the Foot Rests, loosen but don't remove the bolt that secures the lower section of each Foot Rest to the upper half. See Figure 2, below.

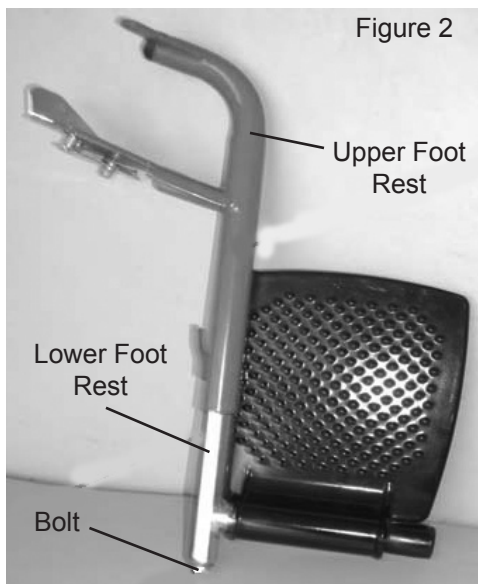

2. Reposition lower section of Foot Rest to desired height. Tighten bolt until upper section is secured at spot.
3. **NOTE:** The Wheelchair may be used without Foot Rests by persons able to use their feet to self-propel chair.

## Replacing Seat

1. Wheelchair uses ten screws and washers to secure Seat (6) to frame.
2. To replace the Seat, remove the screws and washers that secure the Seat to the cross braces. See Figure 3, above. **Please Note:** Seat height cannot be adjusted.
3. Remove plate from Seat sleeve.
4. To install new Seat, insert plate into sleeve and fasten Seat to cross bars using ten screws and washers.

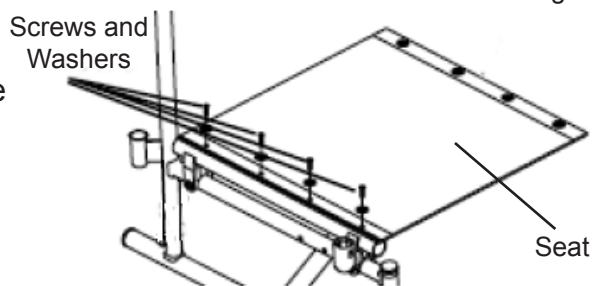

## Replacing Back Pad

1. Remove the eight screws and washers that secure the Back Pad (7) to the back of the Handles (8).
2. Remove upholstery from Wheelchair and, using the screws and washers, securely fasten the new back upholstery to the back of the Handles. See Figure 4, below.

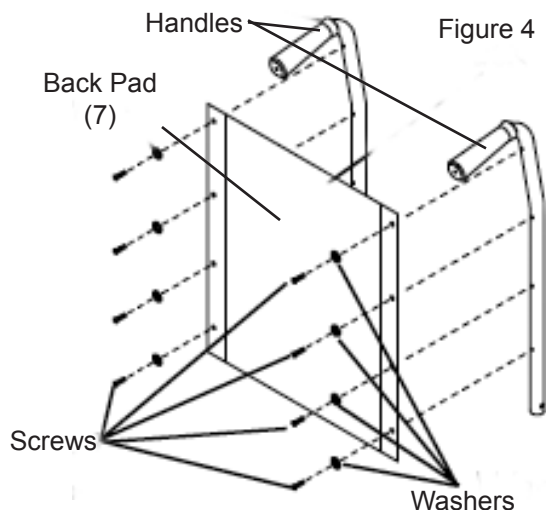

## Adjust and Replacing Front Wheels

1. Should the Casters need to be adjusted, first tip back of Wheelchair to floor.
2. To tighten or loosen Casters, remove the Dust Cover from the top of the Caster Head tube and adjust Locknut allowing for looser or tighter Caster

swing (Casters should swing down to one side and immediately rest after being held straight at the top of the arc.) Too much swing indicates Casters need to be tightened; not enough swing means Casters should be loosened. See Figure 5, below.

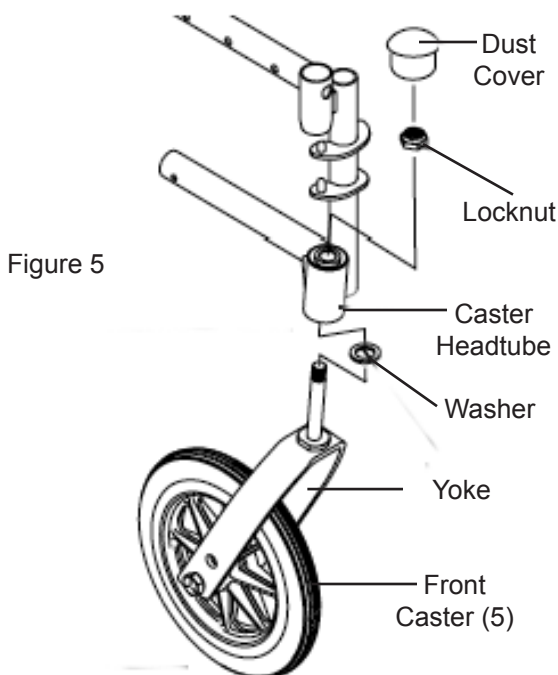
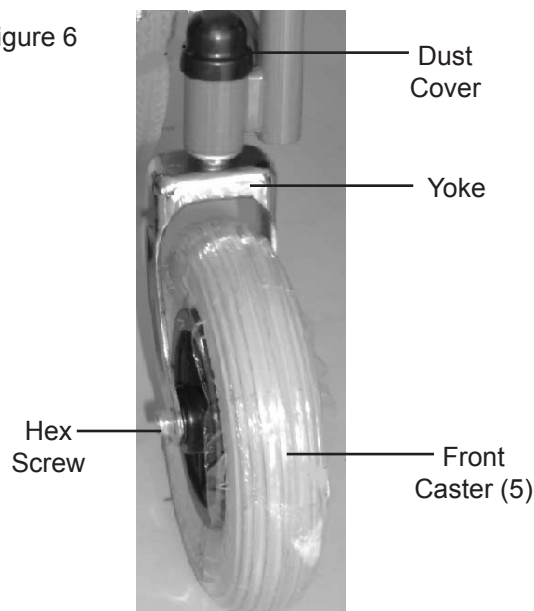

Figure 5

3. Test Wheelchair for maneuverability. Once both Casters are properly readjusted, snap Dust Cover back into place over Locknut.
4. To replace Casters, remove Hex Screws, Washers, and Locknut holding each Caster in place in the Yoke.
5. Set new Wheel in the Yoke and fasten in place using Hex Screws, Washers and Locknuts. See Figure 6, above.

Figure 6



### Adjusting Rear Wheel Locks

1. **WARNING!** Do not attempt to stop a moving Wheelchair with Wheel Locks (4). Wheel Locks are NOT brakes.
2. To adjust Wheel Locks, disengage lock and loosen bolt and locknut that secure Rear Wheel (3) to frame.
3. Reposition Wheel Lock so that when brake is engaged, lock shoe presses down 1/8" onto Rear Wheel, holding Wheelchair in place. See Figure 7.

Figure 7

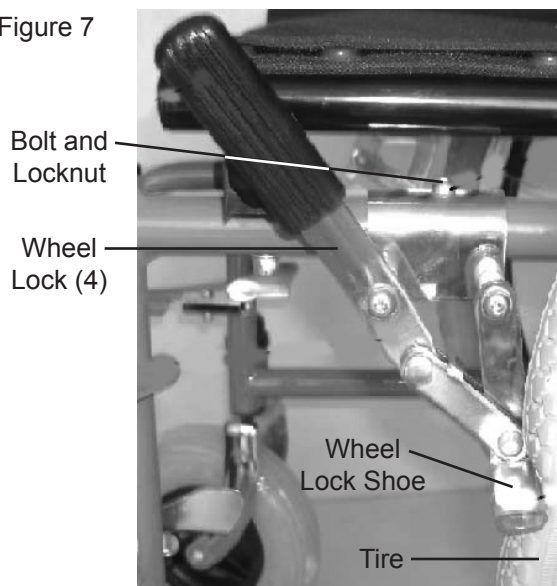



4. Securely tighten the bolt and locknut, securing the Wheel Lock to the frame.
5. Repeat the above steps until BOTH Wheel Locks engage the lock shoe at least an 1/8" into the tire when the Wheel Lock handle is pulled, and HOLDS the occupied Wheelchair in place when used.
6. If the 1/8" measurement cannot be reached, contact a qualified service technician.

---

## MAINTENANCE AND SERVICING

---



Procedures not specifically explained in this manual must be performed only by a qualified technician.

### **⚠️ WARNING**

**TO PREVENT  
SERIOUS INJURY**

**FROM WHEELCHAIR  
FAILURE:**

**Do not use damaged equipment. If abnormal noise or vibration occurs, have the problem corrected before further use.**

---

### **Cleaning, Maintenance, and Lubrication**

---

1. **BEFORE EACH USE**, inspect the general condition of the Wheelchair. Check for loose hardware, misalignment or binding of moving parts, cracked or broken parts, and any other condition that may affect its safe operation. **DO NOT USE A DAMAGED WHEELCHAIR.**
2. **BEFORE EACH USE**, examine the Wheel Locks for proper operation. Make sure to adjust both Wheel Locks evenly. **DO NOT USE A WHEELCHAIR WITH DAMAGED OR MALFUNCTIONING WHEEL LOCKS.**
3. **Keep the rubber Rear Wheels free of oil grease, dirt and debris at all times.**
4. **To clean:** Wipe with clean, warm water and a mild detergent. Then dry. **Do not use solvents.**

5. **WHEN STORING**, fold the Wheelchair according to the instructions detailed in this manual and store in a safe, secure location out of reach of children and non-authorized users.

6. **⚠WARNING! All maintenance, service or repairs must be performed only by a qualified service technician.**

### Troubleshooting

<b>Problem</b>	<b>Possible Causes</b>	<b>Likely Solutions</b>
Wheel Lock not functioning properly.	Proper 1/8" distance between Wheel Lock Shoe and Tire cannot be achieved.	Adjustment to Wheel Lock required. Contact qualified service technician.
Wheel Chair is turning too far to right/left.	Front Wheel Casters not adjusted properly.	Adjust Front Wheel Casters and Nut until they swivel properly with equal free play.
Not enough support to occupant's back.	Back Pad is torn or damaged.	Replace Back Pad
Wheelchair not folding properly.	1. Footrests are not raised. 2. Seat is damaged or torn.	1. Raise the Footrests. 2. Replace Seat.



**Follow all safety precautions whenever diagnosing or servicing the Wheelchair.**

### PLEASE READ THE FOLLOWING CAREFULLY

THE MANUFACTURER AND/OR DISTRIBUTOR HAS PROVIDED THE PARTS LIST AND ASSEMBLY DIAGRAM IN THIS MANUAL AS A REFERENCE TOOL ONLY. NEITHER THE MANUFACTURER OR DISTRIBUTOR MAKES ANY REPRESENTATION OR WARRANTY OF ANY KIND TO THE BUYER THAT HE OR SHE IS QUALIFIED TO MAKE ANY REPAIRS TO THE PRODUCT, OR THAT HE OR SHE IS QUALIFIED TO REPLACE ANY PARTS OF THE PRODUCT. IN FACT, THE MANUFACTURER AND/OR DISTRIBUTOR EXPRESSLY STATES THAT ALL REPAIRS AND PARTS REPLACEMENTS SHOULD BE UNDERTAKEN BY CERTIFIED AND LICENSED TECHNICIANS, AND NOT BY THE BUYER. THE BUYER ASSUMES ALL RISK AND LIABILITY ARISING OUT OF HIS OR HER REPAIRS TO THE ORIGINAL PRODUCT OR REPLACEMENT PARTS THERETO, OR ARISING OUT OF HIS OR HER INSTALLATION OF REPLACEMENT PARTS THERETO.

**Record Product's Serial Number Here:** \_\_\_\_\_

**Note:** If product has no serial number, record month and year of purchase instead.

**Note:** Some parts are listed and shown for illustration purposes only, and are not available individually as replacement parts.

## PARTS LIST AND ASSEMBLY DIAGRAM

Part	Description	Qty.
1	Detachable Footrest	2
2	Footplate	2
3	Rear Wheel	2
4	Wheel Lock	2
5	Front Casters	2

Part	Description	Qty.
6	Seat	1
7	Back Pad	1
8	Handles	2
9	Frame	1
10	Armrest Pad	2

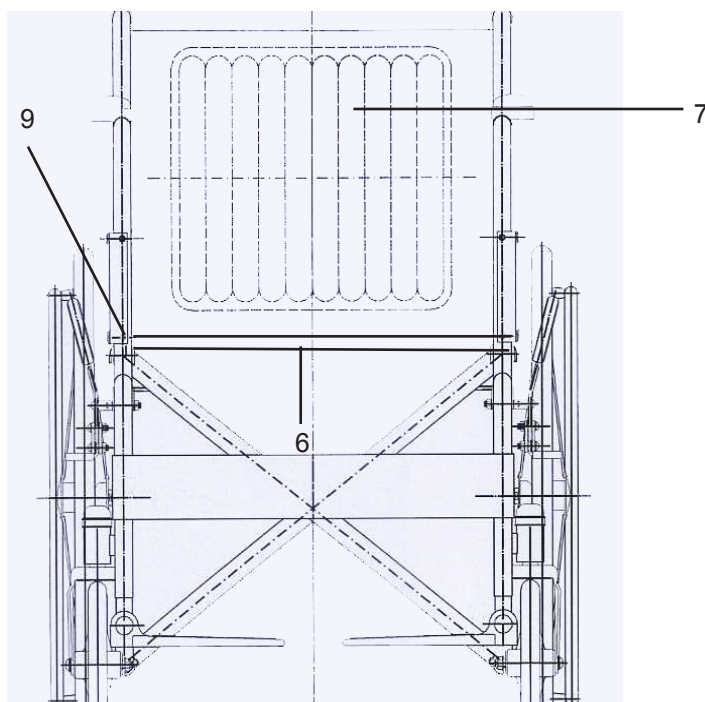
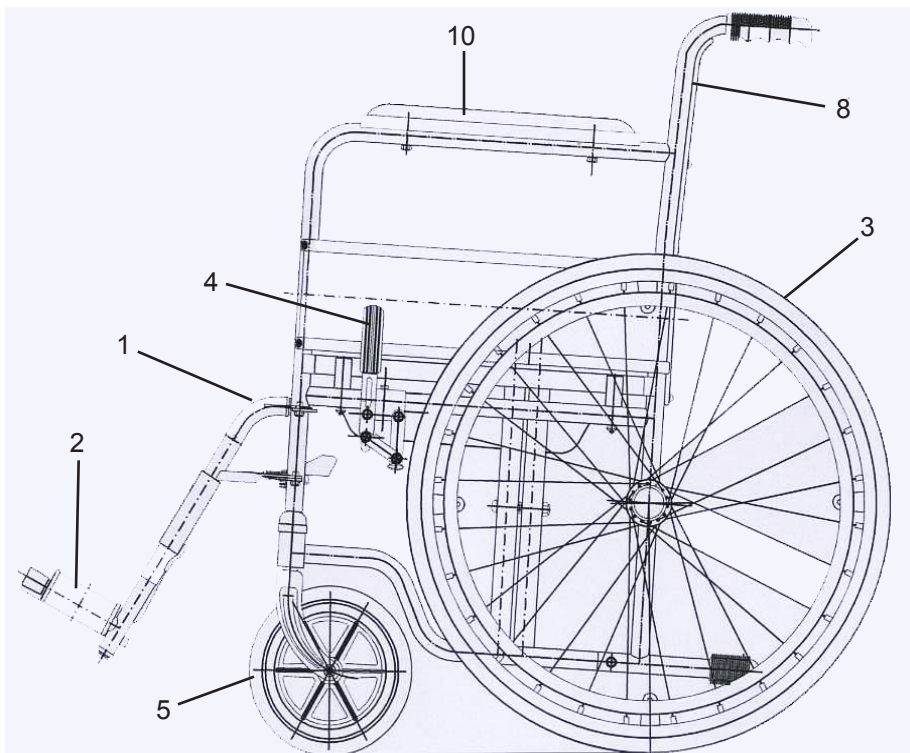

---

## LIMITED 1 YEAR WARRANTY

---

Harbor Freight Tools Co. makes every effort to assure that its products meet high quality and durability standards, and warrants to the original purchaser that this product is free from defects in materials and workmanship for the period of one year from the date of purchase (90 days if used by a professional contractor or if used as rental equipment). This warranty does not apply to damage due directly or indirectly, to misuse, abuse, negligence or accidents, repairs or alterations outside our facilities, normal wear and tear, or to lack of maintenance. We shall in no event be liable for death, injuries to persons or property, or for incidental, contingent, special or consequential damages arising from the use of our product. Some states do not allow the exclusion or limitation of incidental or consequential damages, so the above limitation of exclusion may not apply to you. THIS WARRANTY IS EXPRESSLY IN LIEU OF ALL OTHER WARRANTIES, EXPRESS OR IMPLIED, INCLUDING THE WARRANTIES OF MERCHANTABILITY AND FITNESS.

To take advantage of this warranty, the product or part must be returned to us with transportation charges prepaid. Proof of purchase date and an explanation of the complaint must accompany the merchandise. If our inspection verifies the defect, we will either repair or replace the product at our election or we may elect to refund the purchase price if we cannot readily and quickly provide you with a replacement. We will return repaired products at our expense, but if we determine there is no defect, or that the defect resulted from causes not within the scope of our warranty, then you must bear the cost of returning the product.

This warranty gives you specific legal rights and you may also have other rights which vary from state to state.

**3491 Mission Oaks Blvd. • PO Box 6009 • Camarillo, CA 93011 • (800) 444-3353**